

KM-4457F3C

### Features

- MECHANICALLY AND SPECTRALLY MATCHED TO THE L-610MP4BT/BD PHOTOTRANSISTOR.
- WATER CLEAR LENS .
- HIGH POWER OUTPUT.

### Description

F3 Made with Gallium Arsenide Infrared Emitting diodes.

### Package Dimensions

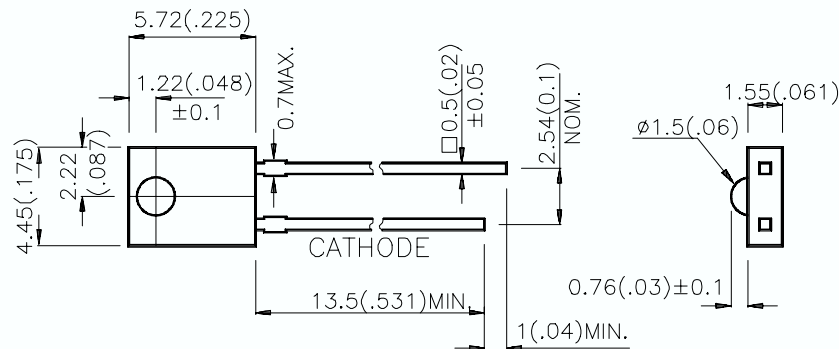

#### Notes:

1. All dimensions are in millimeters (inches).
2. Tolerance is  $\pm 0.25(0.01)$  unless otherwise noted.
3. Lead spacing is measured where the lead emerge package.
4. Specifications are subject to change without notice.

## Selection Guide

Part No.	Dice	Lens Type	Po (mW/sr) @20mA		Viewing Angle
			Min.	Typ.	2θ1/2
KM-4457F3C	GaAs	WATER CLEAR	1.2	3	150°

Note:

1. θ1/2 is the angle from optical centerline where the luminous intensity is 1/2 the optical centerline value.

## Electrical / Optical Characteristics at T<sub>A</sub>=25°C

Item	P/N	Symbol	Typ.	Max.	Unit	Condition
Forward Voltage	F3	V <sub>F</sub>	1.2	1.5	V	IF=20mA
Reverse Current	F3	I <sub>R</sub>	-	10	uA	VR=5V
Junction Capacitance	F3	C	90	-	pF	V=0 f=1MHz
Peak Spectral Wavelength	F3	λ <sub>P</sub>	940	-	nm	IF=20mA
Spectral Bandwidth	F3	Δλ	50	-	nm	IF=20mA

## Absolute Maximum Ratings at T<sub>A</sub>=25°C

Item	Symbol	Maximum Rating	Units
Power Dissipation	P <sub>T</sub>	100	mW
Forward Current	I <sub>F</sub>	50	mA
Peak Forward Current[1]	i <sub>FS</sub>	1.2	A
Reverse Voltage	V <sub>R</sub>	5	V
Operating Temperature	T <sub>A</sub>	-40~ +85	°C
Storage Temperature	T <sub>STG</sub>	-40~ +85	°C
Lead Solder Temperature [2]	260°C For 5 Seconds		

Notes:

- 1/100 Duty Cycle, 10us Pulse Width.
- 4mm below package base.

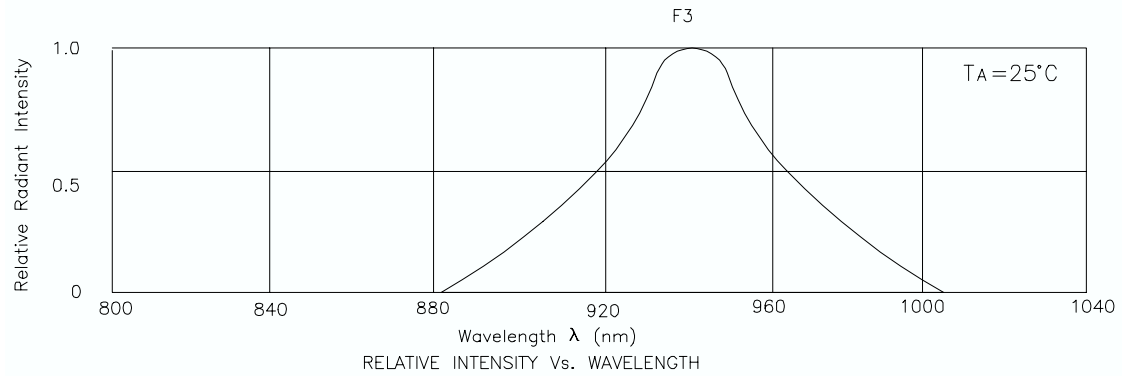

## KM-4457F3C

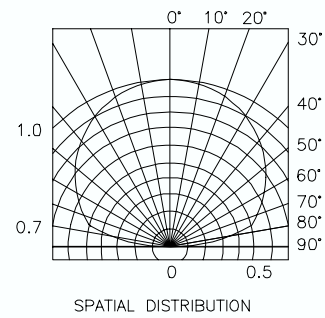
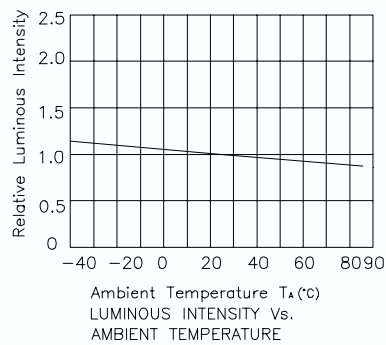
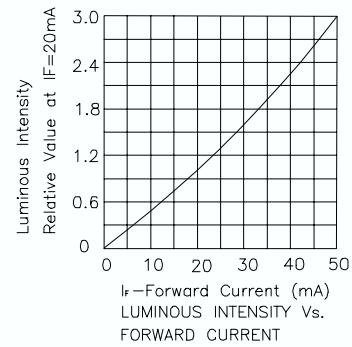
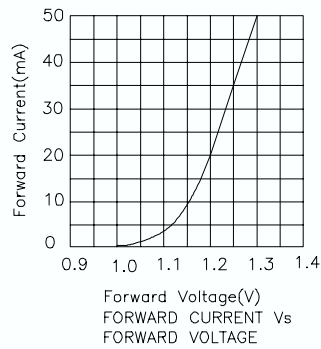

L-34F3C	L-34F3BT
L-34SF4C	L-34SF4BT
L-34SF6C	L-34SF6BT
L-34SF7C	L-34SF7BT

### Features

- MECHANICALLY AND SPECTRALLY MATCHED TO THE L-32P3C PHOTOTRANSISTOR.
- BOTH WATER CLEAR LENS AND BLUE TRANSPARENT LENS AVAILABLE HIGH POWER OUTPUT.

### Description

F3 Made with Gallium Arsenide Infrared Emitting diodes.  
 SF4 and SF6 and SF7 Made with Gallium Aluminum Arsenide Infrared Emitting diodes.

### Package Dimensions

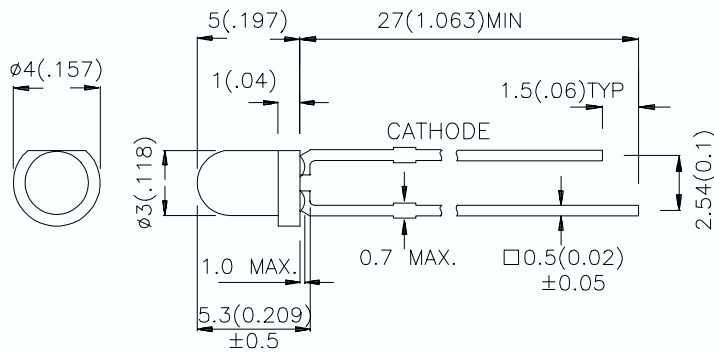

#### Notes:

1. All dimensions are in millimeters (inches).
2. Tolerance is  $\pm 0.25(0.01)$  unless otherwise noted.
3. Lead spacing is measured where the lead emerge package.
4. Specifications are subject to change without notice.

## Selection Guide

Part No.	Dice	Lens Type	Po (mW/sr) @20mA		Po (mW/sr) @50mA		Viewing Angle
			Min.	Typ.	Min.	Typ.	2 $\theta$ 1/2
L-34F3C	GaAs	WATER CLEAR	2	10	5	20	50°
L-34F3BT	GaAs	BLUE TRANSPARENT	2	5	8	20	50°
L-34SF4C	GaAlAs	WATER CLEAR	2	10	5	20	50°
L-34SF4BT	GaAlAs	BLUE TRANSPARENT	2	4	8	20	50°
L-34SF6C	GaAlAs	WATER CLEAR	7	15	10	40	50°
L-34SF6BT	GaAlAs	BLUE TRANSPARENT	7	15	10	40	50°
L-34SF7C	GaAlAs	WATER CLEAR	7	18	10	45	50°
L-34SF7BT	GaAlAs	BLUE TRANSPARENT	7	18	10	45	50°

Note:

1.  $\theta$ 1/2 is the angle from optical centerline where the luminous intensity is 1/2 the optical centerline value.

## Electrical / Optical Characteristics at T<sub>A</sub>=25°C

Item	P/N	Symbol	Typ.	Max.	Unit	Condition
Forward Voltage	F3 SF4 SF6 SF7	V <sub>F</sub>	1.2 1.3 1.35 1.4	1.5 1.7 1.6 1.8	V	IF=20mA
Reverse Current	F3 SF4 SF6 SF7	I <sub>R</sub>	-	10 10 10 10	uA	VR=5V
Junction Capacitance	F3 SF4 SF6 SF7	C	90 90 30 30	-	pF	V=0 f=1MHz
Peak Spectral Wavelength	F3 SF4 SF6 SF7	$\lambda$ P	940 880 860 850	-	nm	IF=20mA
Spectral Bandwidth	F3 SF4 SF6 SF7	$\Delta\lambda$	50 50 50 41	-	nm	IF=20mA

## Absolute Maximum Ratings at $T_A=25^\circ\text{C}$

Item	Symbol	F3&SF4	SF6&SF7	Units
Power Dissipation	$P_d$	100	100	mW
Forward Current	$I_F$	50	50	mA
Peak Forward Current	$I_p$	1.2	1	A
Reverse Voltage	$V_R$	5	5	V
Operating Temperature	$T_{opr}$	-40~ +85	-40~ +85	$^\circ\text{C}$
Storage Temperature	$T_{stg}$	-40~ +85	-40~ +85	$^\circ\text{C}$

**Notes:**

- 1/10 Duty Cycle, 0.1ms Pulse Width.
2. 4mm below package base.

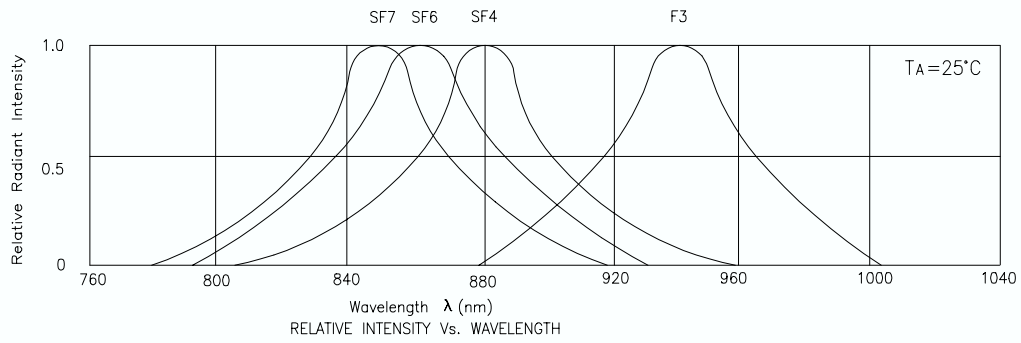

## L-34F3C, L-34F3BT

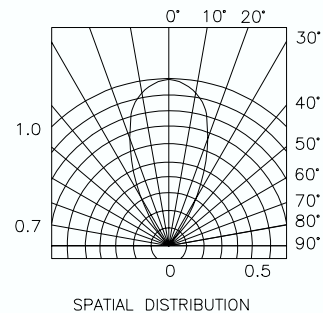
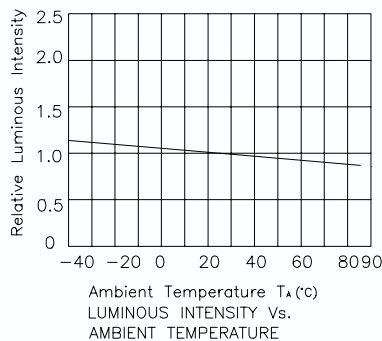
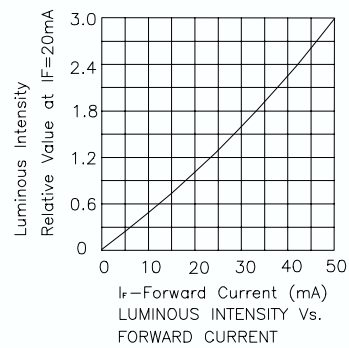
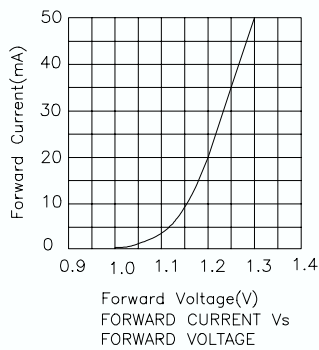

## L-34SF4C, L-34SF4BT

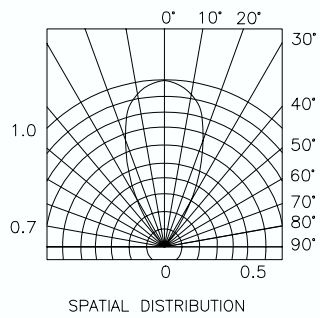
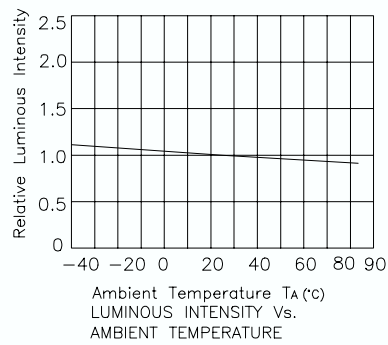
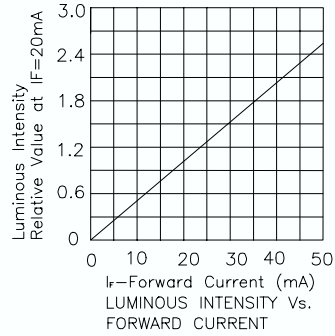
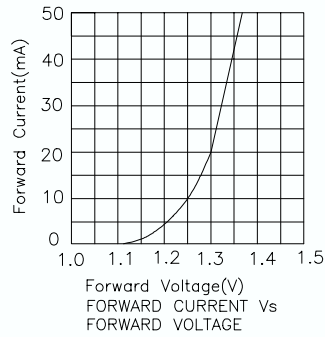

## L-34SF6C, L-34SF6BT

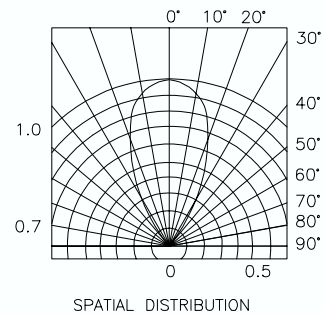
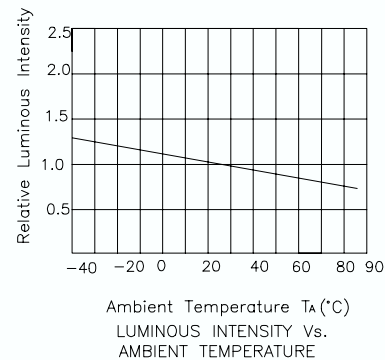
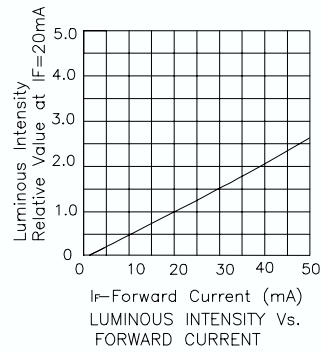
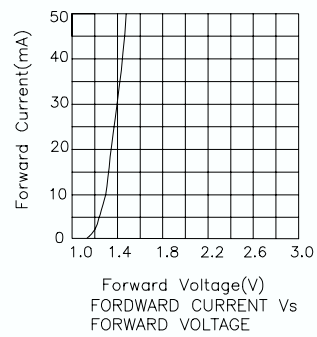

## L-34SF7C, L-34SF7BT

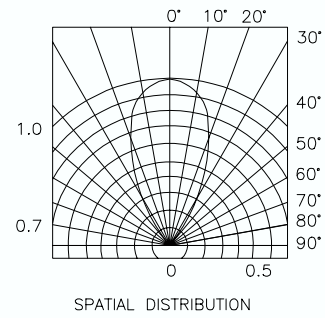
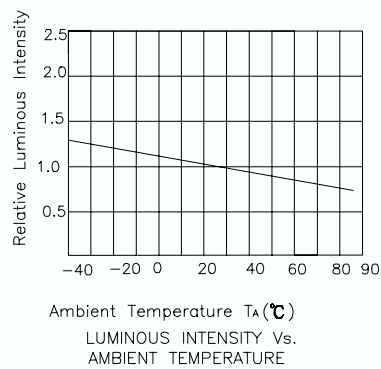
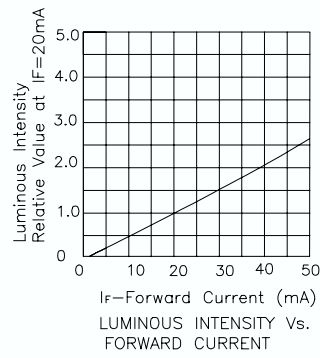
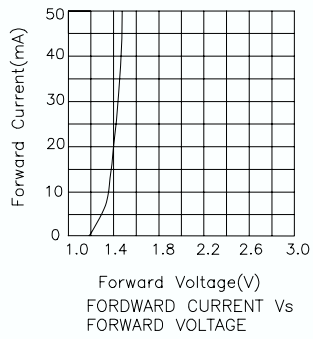

L-610MP4BT/BD

### Features

- MECHANICALLY AND SPECTRALLY MATCHED TO THE KM-4457 INFRARED EMITTING LED LAMP SERIES.
- BLACK PLASTIC PACKAGE.
- COUPLED WITH KM-4457 INFRARED EMITTING LED LAMP SERIES FOR MOUSE APPLICATION.

### Description

Made with NPN silicon phototransistor chips.

### Package Dimensions

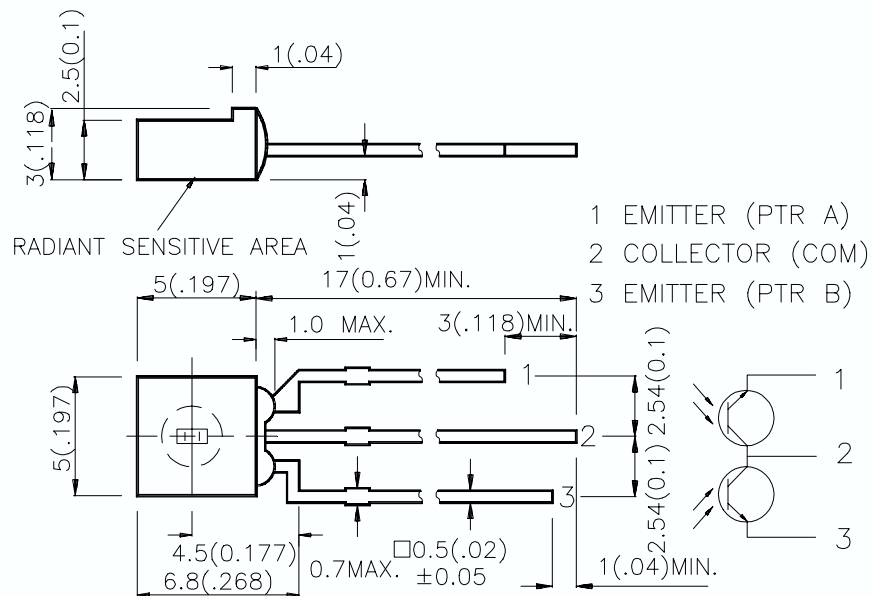

### Notes:

1. All dimensions are in millimeters (inches).
2. Tolerance is  $\pm 0.25(0.01)$  unless otherwise noted.
3. Lead spacing is measured where the lead emerge package.
4. Specifications are subject to change without notice.

## Absolute Maximum Rating at $T_A=25^{\circ}\text{C}$

Parameter	Maximum Ratings
Collector-to-Emitter Breakdown Voltage	30V
Emitter-to-Collector Breakdown Voltage	5V
Power Dissipation at (or below) $25^{\circ}\text{C}$ Free Air Temperature	100mW
Operating Temperature Range	$-55^{\circ}\text{C} \sim +100^{\circ}\text{C}$
Storage Temperature Range	$-55^{\circ}\text{C} \sim +100^{\circ}\text{C}$
Lead Soldering Temperature(4mm For 5sec)	$260^{\circ}\text{C}$

## Electrical And Radiant Characteristics at $T_A=25^{\circ}\text{C}$

Symbol	Parameter	Min.	Typ.	Max.	Unit	Test Condition
$V_{BR\text{CEO}}$	Collector-to-Emitter Breakdown Voltage	30	-	-	V	$I_C=100\mu\text{A}$ $E_e=0\text{mW}/\text{cm}^2$
$V_{BR\text{ECO}}$	Emitter-to-Collector Breakdown Voltage	5	-	-	V	$I_E=100\mu\text{A}$ $E_e=0\text{mW}/\text{cm}^2$
$V_{CE(\text{SAT})}$	Collector-to-Emitter Saturation Voltage	-	-	0.4	V	$I_C=500\mu\text{A}$ $E_e=5\text{mW}/\text{cm}^2$
$I_{\text{CEO}}$	Collector Dark Current	-	-	100	nA	$V_{CE}=10\text{V}$ $E_e=0\text{mW}/\text{cm}^2$
$T_R$	Rise Time (10% to 90%)	-	16	-	us	$V_{CE}=5\text{V}$ $I_C=1\text{mA}$ $R_L=1\text{K}\Omega$
$T_F$	Fall Time (90% to 10%)	-	18	-	us	
$I_{(\text{ON})}$	On State Collector Current	0.1	0.5	-	mA	$V_{CE}=5\text{V}$ , $E_e=1\text{mW}/\text{cm}^2$ , $\lambda=940\text{nm}$
R	On State Collector Current	0.8	1	1.25	mA	$I_C(\text{on})(a) / I_C(\text{on})(b)$

L-934MBDK BLUE

L-934MBTK BLUE

L-934MBCK BLUE

### Features

- LOW POWER CONSUMPTION.
- SOLID STATE BLUE LIGHT SOURCE.
- SUITABLE FOR FULL COLOR LED DISPLAYS AND INDICATORS DIAGNOSTIC/ANALYTICAL EQUIPMENT.

### Description

The Blue source color devices are made with GaN on SiC Light Emitting Diode.

Static electricity and surge damage the LEDs. It is recommended to use a wrist band or anti-electrostatic glove when handling the LEDs.

All devices, equipment and machinery must be electrically grounded.

### Package Dimensions

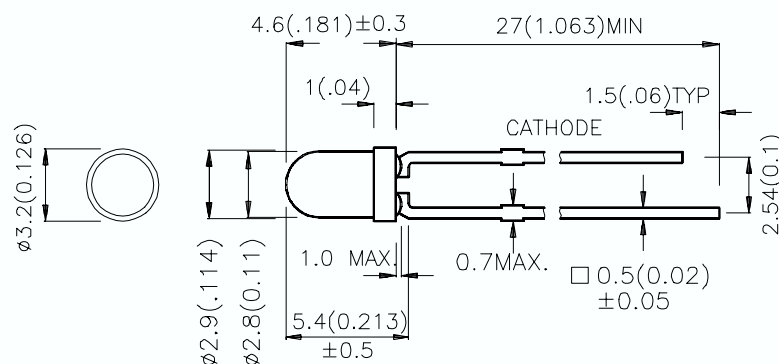

#### Notes:

1. All dimensions are in millimeters (inches).
2. Tolerance is  $\pm 0.25(0.01)$  unless otherwise noted.
3. Lead spacing is measured where the lead emerge package.
4. Specifications are subject to change without notice.

## Selection Guide

Part No.	Dice	Case-Color	Iv (mcd) @ 20 mA		Viewing Angle
			Min.	Typ.	2θ1/2
L-934MBDK	Blue (GaN)	BLUE DIFFUSED	8	25	60°
L-934MBTK	Blue (GaN)	BLUE TRANSPARENT	10	40	20°
L-934MBCK	Blue (GaN)	WATER CLEAR	20	60	20°

Note:

1. θ1/2 is the angle from optical centerline where the luminous intensity is 1/2 the optical centerline value.

## Electrical / Optical Characteristics at T<sub>A</sub>=25°C

Symbol	Parameter	Device	Typ.	Max.	Units	Test Conditions
λ <sub>peak</sub>	Peak Wavelength	Blue	430		nm	IF=20mA
λ <sub>D</sub>	Dominate Wavelength	Blue	455		nm	IF=20mA
Δλ <sub>1/2</sub>	Spectral Line Halfwidth	Blue	60		nm	IF=20mA
C	Capacitance	Blue	85		pF	VF=0V;f=1MHz
V <sub>F</sub>	Forward Voltage	Blue	4.0	4.5	V	IF=20mA
I <sub>r</sub>	Reverse Current	Blue		10	μA	VR = 5V

## Absolute Maximum Ratings at T<sub>A</sub>=25°C

Parameter	Blue	Units
Power dissipation	105	mW
DC Forward Current	30	mA
Peak Forward Current [1]	150	mA
Reverse Voltage	5	V
Operating Temperature	-40°C To +80°C	
Storage Temperature	-40°C To +85°C	
Lead Solder Temperature [2]	260°C For 5 Seconds	

Notes:

- 1/10 Duty Cycle, 0.1ms Pulse Width.
- 4mm below package base.

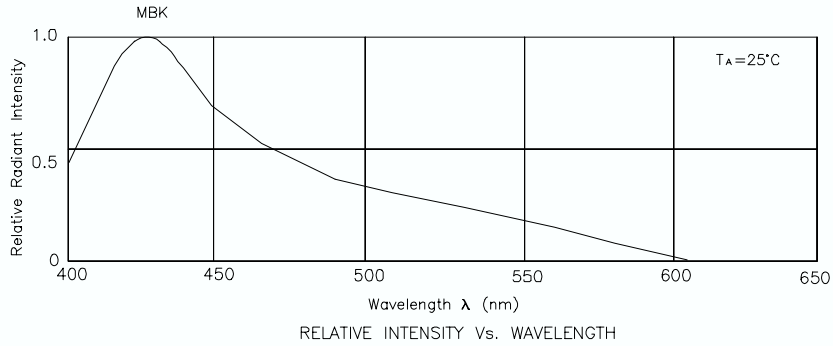

## Blue L-934MBDK,L-934MBTK,L-934MBCK

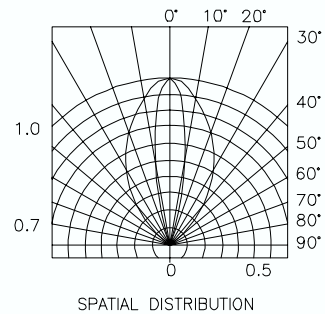
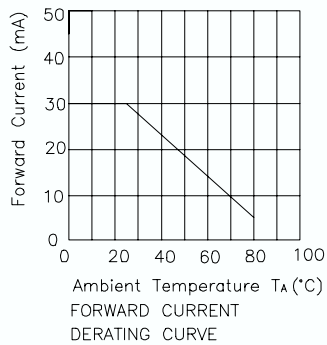
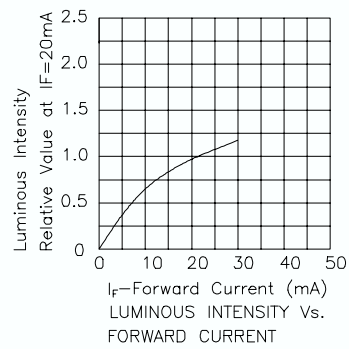
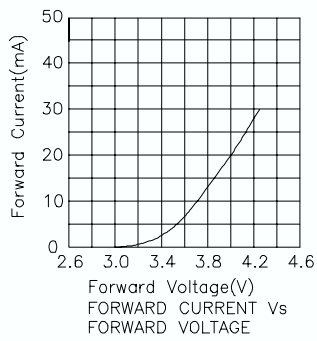

L-934PBC-E BLUE

### Features

- LOW POWER CONSUMPTION.
- SOLID STATE BLUE LIGHT SOURCE.
- SUITABLE FOR FULL COLOR LED DISPLAYS AND INDICATORS DIAGNOSTIC/ANALYTICAL EQUIPMENT.

### Description

The Blue source color devices are made with InGaN on SiC Light Emitting Diode.

### Package Dimensions

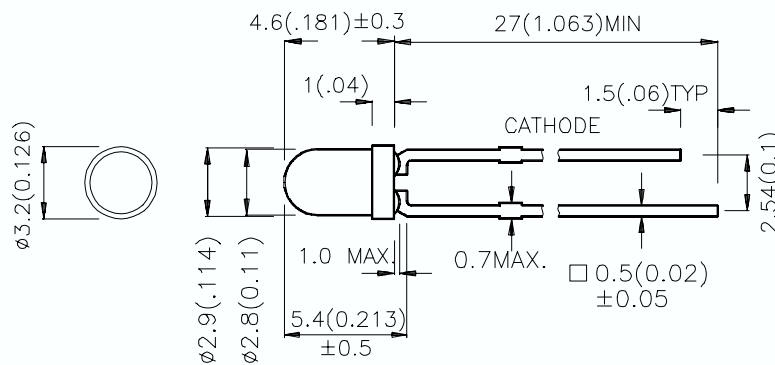

#### Notes:

1. All dimensions are in millimeters (inches).
2. Tolerance is  $\pm 0.25(0.01)$  unless otherwise noted.
3. Lead spacing is measured where the lead emerge package.
4. Specifications are subject to change without notice.

## Selection Guide

Part No.	Dice	Case-Color	Iv (mcd) @ 20 mA		Viewing Angle
			Min.	Typ.	2θ1/2
L-934PBC-E	Blue (InGaN)	WATER CLEAR	380	650	20°

Note:

1. θ1/2 is the angle from optical centerline where the luminous intensity is 1/2 the optical centerline value.

## Electrical / Optical Characteristics at T<sub>A</sub>=25°C

Symbol	Parameter	Device	Typ.	Max.	Units	Test Conditions
λ <sub>peak</sub>	Peak Wavelength	Blue	460		nm	IF=20mA
λ <sub>D</sub>	Dominate Wavelength	Blue	465		nm	IF=20mA
Δλ <sub>1/2</sub>	Spectral Line Halfwidth	Blue	25		nm	IF=20mA
C	Capacitance	Blue	110		pF	VF=0V;f=1MHz
V <sub>F</sub>	Forward Voltage	Blue	3.7	4.1	V	IF=20mA
I <sub>R</sub>	Reverse Current	Blue		10	μA	VR = 5V

## Absolute Maximum Ratings at T<sub>A</sub>=25°C

Parameter	Blue	Units
Power dissipation	120	mW
DC Forward Current	30	mA
Peak Forward Current [1]	160	mA
Reverse Voltage	5	V
Operating/Storage Temperature	-40°C To +85°C	
Lead Solder Temperature [2]	260°C For 5 Seconds	

Notes:

- 1/10 Duty Cycle, 0.1ms Pulse Width.
- 4mm below package base.

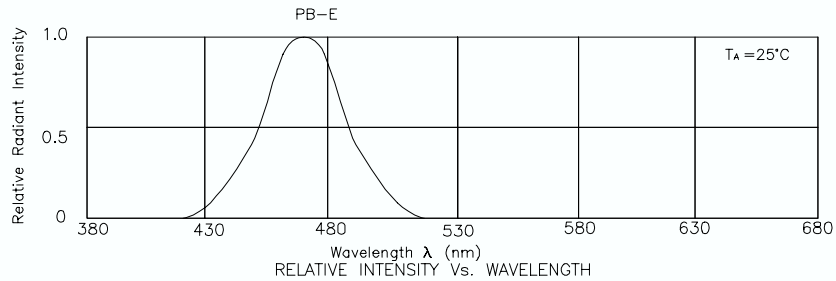

## Blue L-934PBC-E

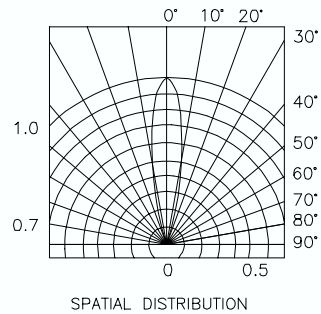
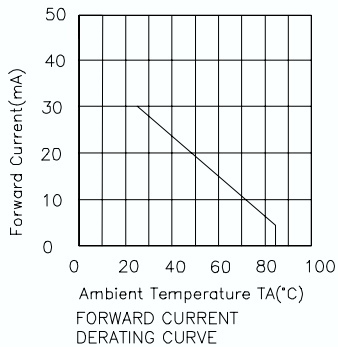
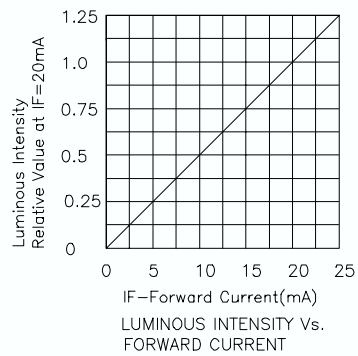
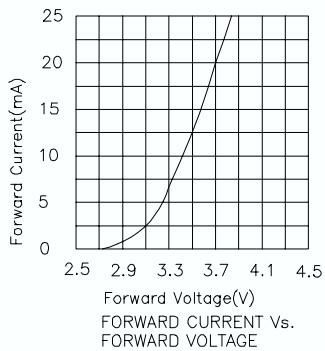

L-32P3C

### Features

- MECHANICALLY AND SPECTRALLY MATCHED TO THE L34 SERIES INFRARED EMITTING LED LAMP.
- WATER CLEAR LENS.

### Description

Made with NPN silicon phototransistor chips.

### Package Dimensions

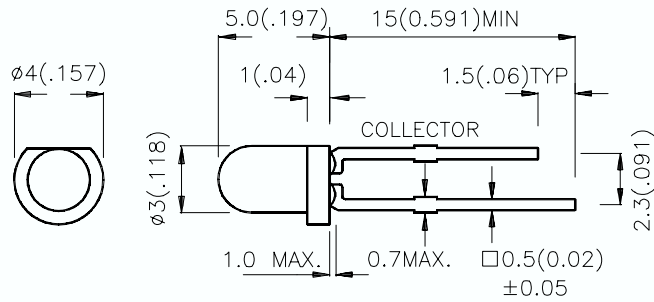

#### Notes:

1. All dimensions are in millimeters (inches).
2. Tolerance is  $\pm 0.25(0.01)$ " unless otherwise noted.
3. Lead spacing is measured where the lead emerge package.
4. Specifications are subjected to change without notice.

## Absolute Maximum Rating at $T_A=25^{\circ}\text{C}$

Parameter	Maximum Ratings
Collector-to-Emitter Breakdown Voltage	30V
Emitter-to-Collector Breakdown Voltage	5V
Power Dissipation at (or below) $25^{\circ}\text{C}$ Free Air Temperature	100mW
Operating Temperature Range	$-40^{\circ}\text{C} \sim +85^{\circ}\text{C}$
Storage Temperature Range	$-40^{\circ}\text{C} \sim +85^{\circ}\text{C}$
Lead Soldering Temperature(4mm For 5sec)	$260^{\circ}\text{C}$

## Electrical And Radiant Characteristics at $T_A=25^{\circ}\text{C}$

Symbol	Parameter	Min.	Typ.	Max.	Unit	Test Condition
$V_{BR\text{CEO}}$	Collector-to-Emitter Breakdown Voltage	30	-	-	V	$I_C=100\mu\text{A}$ $E_e=0\text{mW}/\text{cm}^2$
$V_{BR\text{ECO}}$	Emitter-to-Collector Breakdown Voltage	5	-	-	V	$I_E=100\mu\text{A}$ $E_e=0\text{mW}/\text{cm}^2$
$V_{CE(SAT)}$	Collector-to-Emitter Saturation Voltage	-	-	0.8	V	$I_C=2\text{mA}$ $E_e=20\text{mW}/\text{cm}^2$
$I_{\text{CEO}}$	Collector Dark Current	-	-	100	nA	$V_{CE}=10\text{V}$ $E_e=0\text{mW}/\text{cm}^2$
$T_R$	Rise Time (10% to 90%)	-	3	-	us	$V_{CE}=5\text{V}$ $I_C=1\text{mA}$ $R_L=1\text{K}\Omega$
$T_F$	Fall Time (90% to 10%)	-	3	-	us	
$I_{(ON)}$	On State Collector Current	0.1	0.5	-	mA	$V_{CE}=5\text{V}$ , $E_e=1\text{mW}/\text{cm}^2$ , $\lambda=940\text{nm}$

L-51P3C

### Features

- MECHANICALLY AND SPECTRALLY MATCHED TO THE L-53 SERIES INFRARED EMITTING LED LAMP.
- WATER CLEAR LENS.

### Description

Made with NPN silicon phototransistor chips.

### Package Dimensions

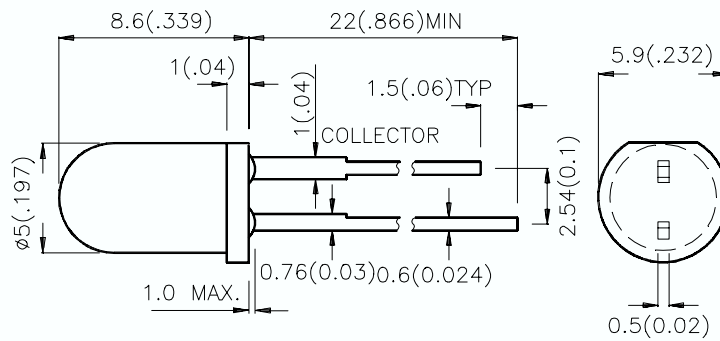

#### Notes:

1. All dimensions are in millimeters (inches).
2. Tolerance is  $\pm 0.25(0.01)$  unless otherwise noted.
3. Lead spacing is measured where the lead emerge package.
4. Specifications are subject to change without notice.

## Absolute Maximum Rating at $T_A=25^\circ\text{C}$

Parameter	Maximum Ratings
Collector-to-Emitter Breakdown Voltage	30V
Emitter-to-Collector Breakdown Voltage	5V
Power Dissipation at (or below) $25^\circ\text{C}$ Free Air Temperature	100mW
Operating Temperature Range	$-40^\circ\text{C} \sim +85^\circ\text{C}$
Storage Temperature Range	$-40^\circ\text{C} \sim +85^\circ\text{C}$
Lead Soldering Temperature(4mm For 5sec)	$260^\circ\text{C}$

## Electrical And Radiant Characteristics at $T_A=25^\circ\text{C}$

Symbol	Parameter	Min.	Typ.	Max.	Unit	Test Condition
$V_{BR\text{CEO}}$	Collector-to-Emitter Breakdown Voltage	30	-	-	V	$I_C=100\mu\text{A}$ $E_e=0\text{mW}/\text{cm}^2$
$V_{BR\text{ECO}}$	Emitter-to-Collector Breakdown Voltage	5	-	-	V	$I_E=100\mu\text{A}$ $E_e=0\text{mW}/\text{cm}^2$
$V_{CE(SAT)}$	Collector-to-Emitter Saturation Voltage	-	-	0.8	V	$I_C=2\text{mA}$ $E_e=20\text{mW}/\text{cm}^2$
$I_{\text{CEO}}$	Collector Dark Current	-	-	100	nA	$V_{CE}=10\text{V}$ $E_e=0\text{mW}/\text{cm}^2$
$T_R$	Rise Time (10% to 90%)	-	3	-	us	$V_{CE}=5\text{V}$ $I_C=1\text{mA}$ $R_L=1\text{K}\Omega$
$T_F$	Fall Time (90% to 10%)	-	3	-	us	
$I_{(ON)}$	On State Collector Current	0.1	0.5	-	mA	$V_{CE}=5\text{V}$ , $E_e=1\text{mW}/\text{cm}^2$ , $\lambda=940\text{nm}$

L-934MBD BLUE

L-934MBT BLUE

L-934MBC BLUE

### Features

- LOW POWER CONSUMPTION.
- SOLID STATE BLUE LIGHT SOURCE.
- SUITABLE FOR FULL COLOR LED DISIPLAYS AND INDICATORS DIAGNOSTIC/ANALYTICAL EQUIPMENT.

### Description

The Blue source color devices are made with GaN on SiC Light Emitting Diode.

Static electricity and surge damage the LEDs. It is recommended to use a wrist band or anti-electrostatic glove when handling the LEDs.

All devices, equipment and machinery must be electrically grounded.

### Package Dimensions

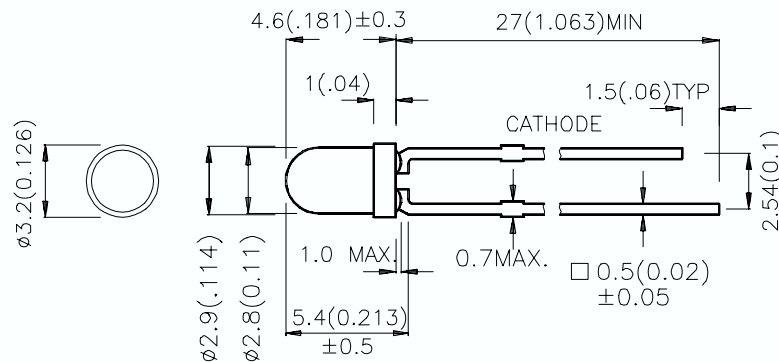

#### Notes:

1. All dimensions are in millimeters (inches).
2. Tolerance is  $\pm 0.25$  (0.01") unless otherwise noted.
3. Lead spacing is measured where the lead emerge package.
4. Specifications are subject to change without notice.

## Selection Guide

Part No.	Dice	Case-Color	Iv (mcd) @ 20 mA		Viewing Angle
			Min.	Typ.	2θ1/2
L-934MBD	Blue (GaN)	BLUE DIFFUSED	20	50	60°
L-934MBT	Blue (GaN)	BLUE TRANSPARENT	40	60	20°
L-934MBC	Blue (GaN)	WATER CLEAR	40	80	20°

Note:

1. θ1/2 is the angle from optical centerline where the luminous intensity is 1/2 the optical centerline value.

## Electrical / Optical Characteristics at T<sub>A</sub>=25°C

Symbol	Parameter	Device	Typ.	Max.	Units	Test Conditions
λ <sub>peak</sub>	Peak Wavelength	Blue	430		nm	IF=20mA
λ <sub>D</sub>	Dominate Wavelength	Blue	455		nm	IF=20mA
Δλ <sub>1/2</sub>	Spectral Line Halfwidth	Blue	60		nm	IF=20mA
C	Capacitance	Blue	65		pF	VF=0V;f=1MHz
V <sub>F</sub>	Forward Voltage	Blue	4.0	4.5	V	IF=20mA
I <sub>r</sub>	Reverse Current	Blue		10	μA	VR = 5V

## Absolute Maximum Ratings at T<sub>A</sub>=25°C

Parameter	Blue	Units
Power dissipation	105	mW
DC Forward Current	30	mA
Peak Forward Current [1]	150	mA
Reverse Voltage	5	V
Operating Temperature	-40°C To +80°C	
Storage Temperature	-40°C To +85°C	
Lead Solder Temperature [2]	260°C For 5 Seconds	

Notes:

1. 1/10 Duty Cycle, 0.1ms Pulse Width.
2. 4mm below package base.

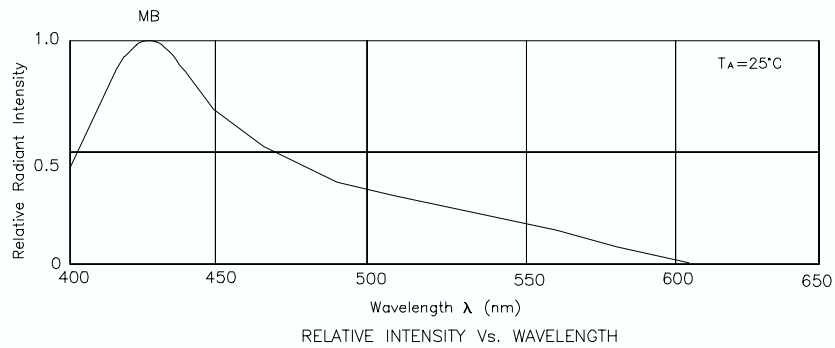

## Blue L-934MBD,L-934MBT,L-934MBC

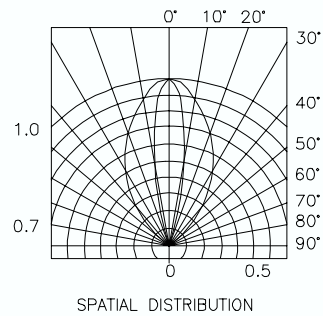
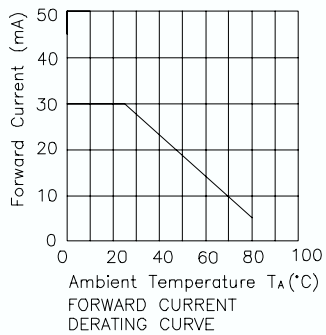
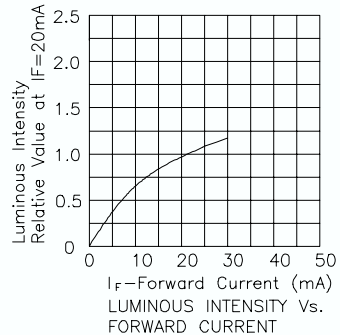
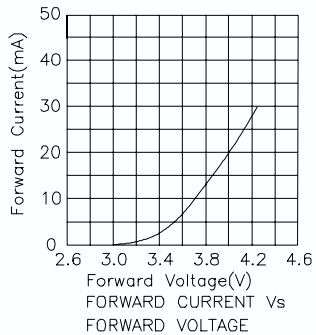



## Optical Characteristics

Part No.	Dice	Lens Type	Iv (mcd) @20mA		Viewing Angle
			Min.	Typ.	2θ1/2
L-934MWC	WHITE ( GaN)	WATER CLEAR	50	180	50°

Note:

1. θ1/2 is the angle from optical centerline where the luminous intensity is 1/2 the optical centerline value.

## Electrical / Optical Characteristics at T<sub>A</sub>=25°C

Symbol	Parameter	Device	Typ.	Max.	Units	Test Conditions
V <sub>F</sub>	Forward Voltage	White	3.8	4.5	V	IF=20mA
I <sub>R</sub>	Reverse Current	White		10	uA	VR = 5V
X	Chromaticity Coordinates	White	0.38			
Y			0.38			
C	Capacitance	White	65		pF	VF=0V, f =1MHz

## Absolute Maximum Ratings at T<sub>A</sub>=25°C

Parameter	White	Units
Power dissipation	105	mW
DC Forward Current	30	mA
Peak Forward Current[1]	100	mA
Reverse Voltage	5	V
Operating Temperature	-40°C To +85°C	
Storage Temperature	-40°C To +85°C	
Lead Solder Temperature[2]	260°C For 5 Seconds	

Notes:

- 1/10 Duty Cycle, 0.1ms Pulse Width.
- 4mm below package base.

## White L-934MWC

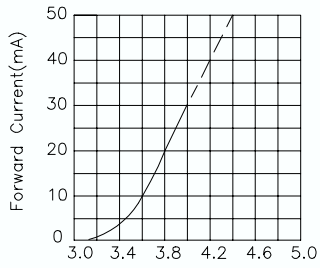

Forward Voltage(V)  
FORWARD CURRENT Vs  
FORWARD VOLTAGE

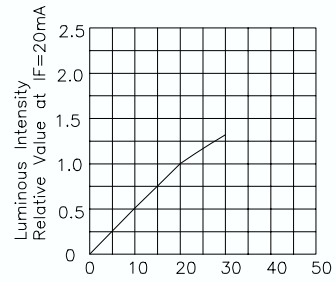

$I_F$ —Forward Current (mA)  
LUMINOUS INTENSITY Vs.  
FORWARD CURRENT

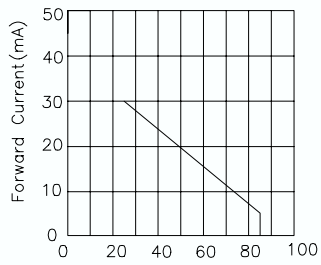

Ambient Temperature  $T_A$ (°C)  
FORWARD CURRENT  
DERATING CURVE

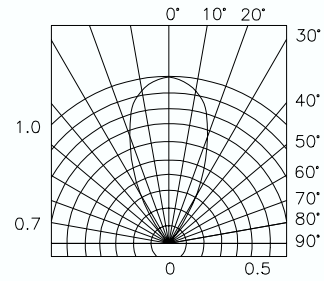

SPATIAL DISTRIBUTION

L-934PWC WHITE

### Features

- HIGH EFFICIENCY.
- WHITE EMISSION,HIGH LUMINOUS INTENSITY.

### Description

The source color devices are made with InGaN on SiC Light Emitting Diode.

### Package Dimensions

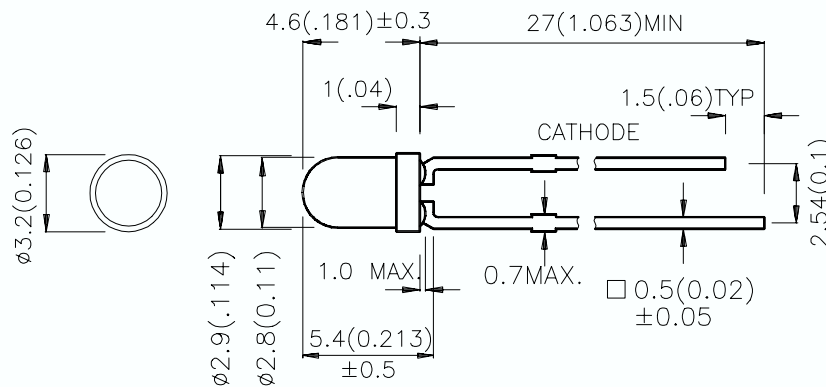

#### Notes:

1. All dimensions are in millimeters (inches).
2. Tolerance is  $\pm 0.25(0.01")$  unless otherwise noted.
3. Lead spacing is measured where the lead emerge package.
4. Specifications are subject to change without notice.

## Optical Characteristics

Part No.	Dice	Lens Type	Iv (mcd) @ 20 mA		Viewing Angle
			Min.	Typ.	2θ1/2
L-934PWC	WHITE (InGaN)	WATER CLEAR	200	600	35°

Note:

1. θ1/2 is the angle from optical centerline where the luminous intensity is 1/2 the optical centerline value.

## Electrical / Optical Characteristics at T<sub>A</sub>=25°C

Symbol	Parameter	Device	Typ.	Max.	Units	Test Conditions
V <sub>F</sub>	Forward Voltage	White	3.6	4.2	V	IF=20mA
I <sub>R</sub>	Reverse Current	White		10	μA	VR = 5V
X	Chromaticity Coordinates	White	0.30			
Y			0.30			
C	Capacitance	White	65		pF	VF=0V, f =1MHz

## Absolute Maximum Ratings at T<sub>A</sub>=25°C

Parameter	White	Units
Power dissipation	102	mW
DC Forward Current	30	mA
Peak Forward Current[1]	100	mA
Reverse Voltage	5	V
Operating Temperature	-40°C To +85°C	
Storage Temperature	-40°C To +85°C	
Lead Solder Temperature[2]	260°C For 5 Seconds	

Notes:

- 1/10 Duty Cycle, 0.1ms Pulse Width.
- 4mm below package base.

## White L-934PWC

